

1. REQUIREMENTS FOR ACQUIRING THE PRODUCT(S) DESCRIBED HEREIN SHALL CONSIST OF THIS SPECIFICATION SHEET AND THE ISSUE OF THE FOLLOWING SPECIFICATION LISTED IN THAT ISSUE OF THE DODDS SPECIFIED IN THE SOLICITATION: MIL-F-18280

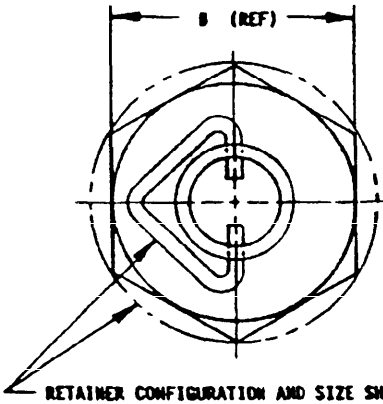

RETAINER CONFIGURATION AND SIZE SHALL BE CONFINED WITHIN THE HEX LIMITS OF THE NUT.

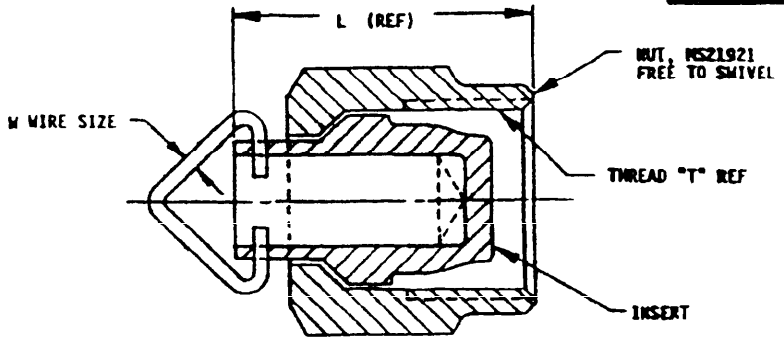

CAP ASSEMBLY

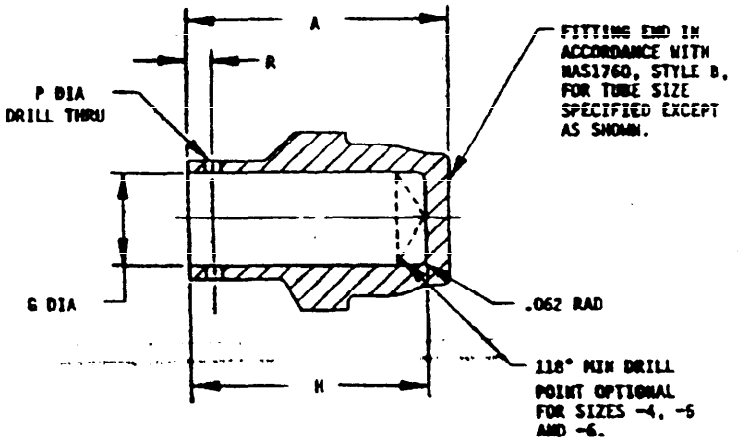
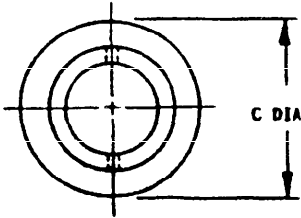

DASH NO.	TUBING O.D.	T THREAD PER MIL-S-8879	A ±.010	B (REF)	C DIA ±.005	G DIA ±.010	H ±.010	L (REF)	P DIA	R	W DIA MIN
-2	1/8	.3125-24UNJF-3B	.600	.375	.256	-	-	.720	.047	.065	.033
-3	3/16	.3750-24UNJF-3B	.672	.438	.318	-	-	.767			
-4	1/4	.4375-20UNJF-3B	.745	.562	.371	.187	.600	.893			
-5	5/16	.5000-20UNJF-3B	.845	.625	.434	.234	.700	.977	.078	.101	.055
-6	3/8	.5625-18UNJF-3B	.885	.688	.490	.297	.740	.965			
-8	1/2	.7500-16UNJF-3B	.935	.875	.670	.406	.790	1.077			
-10	5/8	.8750-14UNJF-3B	1.062	1.000	.786	.600	.917	1.210	.093	.101	.066
-12	3/4	1.0625-12UNJ-3B	1.082	1.250	.960	.656	.937	1.208			
-16	1	1.3125-12UNJ-3B	1.218	1.600	1.210	.906	1.073	1.189			
-20	1-1/4	1.6250-12UNJ-3B	1.193	2.000	1.470	1.093	1.048	1.288	.093	.101	.066
-24	1-1/2	1.8750-12UNJ-3B	1.271	2.250	1.719	1.343	1.125	1.305			

(M) ENTIRE STANDARD REVISED

PREPARING ACTIVITY: NAVY - AS CUSTODIANS: ARMY - AY NAVY - AS AIR FORCE - 99 DLA - REVIEW: USAF-82, ARMY-41, DLA-CS USER: NAVY-05, ARMY-CR, MC, AT, GL, AR, USAF-71 PROJECT NUMBER: 4730-0974	MILITARY SPECIFICATION SHEET TITLE CAP, PRESSURE SEAL, FLARELESS TUBE FITTING	SPECIFICATION SHEET NUMBER MS21914M 6 MAR 90	
		SUPERSEDING MS2194L 26 JUN 81	
		AMSC - N/A JBC 4730	
DISTRIBUTION STATEMENT A. APPROVED FOR PUBLIC RELEASE; DISTRIBUTION IS UNLIMITED.		PAGE 1 OF 2	

THIS SPECIFICATION IS APPROVED FOR USE BY ALL DEPARTMENTS AND AGENCIES OF THE DEPARTMENT OF DEFENSE.

REQUIREMENTS:

1. MATERIAL: NUT AND INSERT: CARBON STEEL - BARS.
ALUMINUM ALLOY - BARS.
CORROSION RESISTANT STEEL - BARS.
TITANIUM ALLOY - BARS.
RETAINER: STEEL WIRE, CLASS 302 ANNEALED PER ASTM A493 OR CLASS 305 PER AMS 5685. } SEE PROCUREMENT SPECIFICATION
2. FINISH: NUT, INSERT AND RETAINER - SEE PROCUREMENT SPECIFICATION.
3. SURFACE TEXTURE IN ACCORDANCE WITH ANSI B46.1.

NOTES:

1. BREAK ALL SHARP EDGES AND REMOVE ALL BURRS AND SLIVERS.
2. DIMENSIONS ARE IN INCHES, UNLESS OTHERWISE SPECIFIED, TOLERANCES: DECIMALS + .005 ANGLES + 1/2°
3. PART NUMBERS
NO CODE LETTER IN PART NUMBER FOR CARBON STEEL.
ADD "D" AFTER DASH NUMBER FOR ALUMINUM ALLOY (2024).
ADD "M" AFTER DASH NUMBER FOR ALUMINUM ALLOY (7075).
ADD "J" AFTER DASH NUMBER FOR CORROSION RESISTANT STEEL TYPE 304.
ADD "K" AFTER DASH NUMBER FOR CORROSION RESISTANT STEEL TYPE 316.
ADD "R" AFTER DASH NUMBER FOR CORROSION RESISTANT STEEL TYPE 321.
ADD "T" AFTER DASH NUMBER FOR TITANIUM ALLOY (6AL-4V).

EXAMPLES OF PART NUMBERS

- MS21914-4 - CAP, CARBON STEEL.
- MS21914-4D - CAP, ALUMINUM ALLOY (2024).
- MS21914-4M - CAP, ALUMINUM ALLOY (7075).
- MS21914-4J - CAP, CORROSION RESISTANT STEEL, TYPE 304.
- MS21914-4K - CAP, CORROSION RESISTANT STEEL, TYPE 316.
- MS21914-4R - CAP, CORROSION RESISTANT STEEL, TYPE 321.
- MS21914-4T - CAP, TITANIUM ALLOY (6AL-4V).

4. PARTS ARE NOT TO BE MANUFACTURED FROM TYPE 347 CRES AFTER 31 DEC 1991. HOWEVER, CODE "S", TYPE 347 CRES PARTS MAY BE USED UNTIL EXISTING STOCKS ARE DEPLETED.
5. TITANIUM IS NOT RECOMMENDED FOR USE IN OXYGEN SYSTEMS.
6. IN THE EVENT OF A CONFLICT BETWEEN THE TEXT OF THIS STANDARD AND THE REFERENCES CITED HEREIN, THE TEXT OF THIS STANDARD SHALL TAKE PRECEDENCE.
7. REFERENCED GOVERNMENT (OR NON-GOVERNMENT) DOCUMENTS OF THE ISSUE LISTED IN THAT ISSUE OF THE DEPARTMENT OF DEFENSE INDEX OF SPECIFICATIONS AND STANDARDS (DoD-ISS) SPECIFIED FORM A PART OF THIS STANDARD TO THE EXTENT SPECIFIED HEREIN.

THE REQUIREMENTS FOR ACQUIRING THE PRODUCT(S) DESCRIBED HEREIN SHALL CONSIST OF THIS SPECIFICATION SHEET AND THE ISSUE OF THE FOLLOWING SPECIFICATION LISTED IN THAT ISSUE OF THE DODISS SPECIFIED IN THE SOLICITATION: MIL-F-18280

THIS SPECIFICATION IS APPROVED FOR USE BY ALL DEPARTMENTS AND AGENCIES OF THE DEPARTMENT OF DEFENSE.

PREPARING ACTIVITY: NAVY - AS CUSTODIANS: ARMY - AY NAVY - AS AIR FORCE - 99 DLA -		MILITARY SPECIFICATION SHEET		SPECIFICATION SHEET NUMBER MS21914M 6 MAR 90	
REVIEW: USAF-82, ARMY-81, DLA-CS USER: NAVY-05, ARMY-CR, NE, AT, GL, AR, USAF-71 PROJECT NUMBER: 4730-0974		TITLE <p style="text-align: center;">CAP, PRESSURE SEAL, FLARELESS TUBE FITTING</p>		SUPERSEDING MS21914L 26 JUN 81	
DISTRIBUTION STATEMENT A. APPROVED FOR PUBLIC RELEASE; DISTRIBUTION IS UNLIMITED.				AMSC - 00/R TBC 4730	
				PAGE 2 OF 2	