

USER SYMBOLS:  
AIR FORCE - 82  
REVIEWER SYMBOLS:  
AIR FORCE - 99  
NAVY - MC, SF, OS  
COAST GUARD - CG  
MARINE CORPS - MC

"Review/ear information is current as of the date of this document.  
For future consideration of changes to this document, draft circulation  
should be based on the information in the current DODISS."

DISTRIBUTION STATEMENT A. APPROVED FOR PUBLIC RELEASE. DISTRIBUTION IS UNLIMITED.  
This military standard is approved for use by all Departments  
B. Agencies of the Department of Defense. Selection for all new  
engineering and design applications and for repetitive use shall  
be made from this document.

ANSC W/A

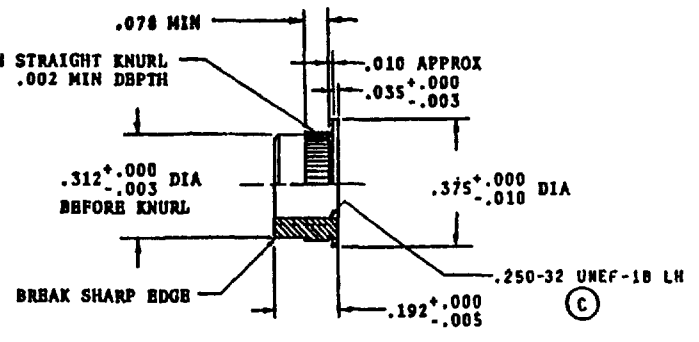
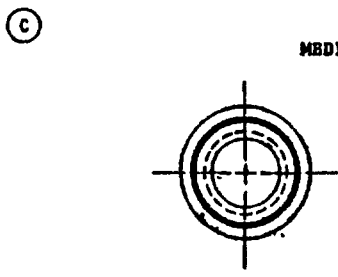

-2 COLLAR

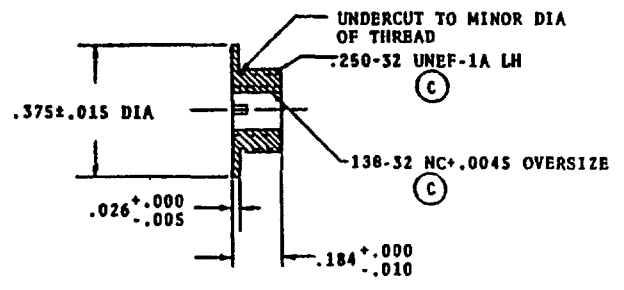
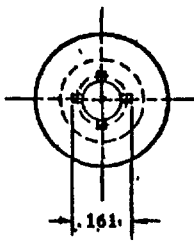

-3, -6 FLANGE

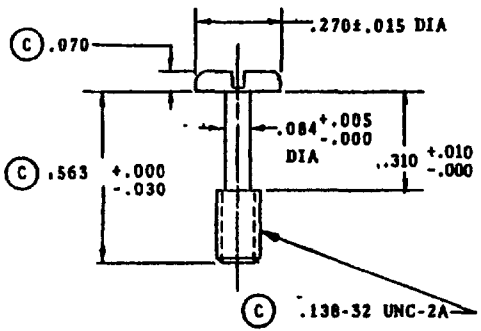

-4, -7 CAPTIVE SCREW, SLOTTED HEAD

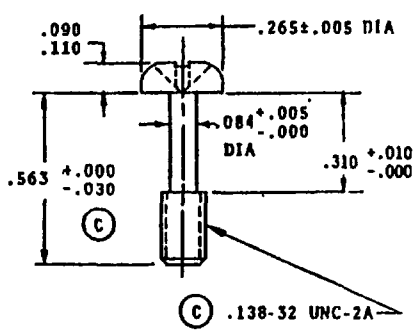

-9, -11 CAPTIVE SCREW, PHILLIPS HEAD

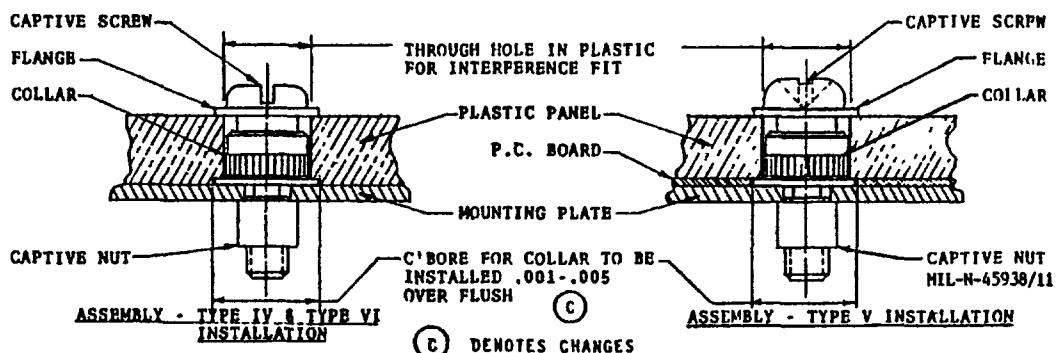

(C) DENOTES CHANGES

P.A. NAVY - AS Other Cust	TITLE (C) SCREW ASSEMBLY, PANEL	MILITARY STANDARD	
		MS 3498	
PROCUREMENT SPECIFICATION MIL-P-7786	SUPERSEDES. MS25381	SHEET 1	OF 2

DD FORM 672-1 (Coordinated)  
1 MAR 72

PREVIOUS EDITIONS OF THIS FORM ARE OBSOLETE

PROJECT NO. 6220-0343

ENGINEERING SPECIFICATIONS

APPROVED 15 MAR 1971 REVISED (B) 30 DEC 76 (C) 24 JUL 87

REVIEWER SYMBOLS:  
AIR FORCE - 99  
NAVY - MC, SH, OS  
COAST GUARD - CG  
MARINE CORPS - MC

\*Review/user information is current as of the date of this document.  
For future coordination of changes to this document, direct circulation  
should be based on the information in the current "ODISS".

DISTRIBUTION STATEMENT APPROVED FOR PUBLIC RELEASE. DISTRIBUTION IS UNLIMITED.  
This military standard is approved for use by all Departments  
& Agencies of the Department of Defense. Selection for all new  
engineering and design applications and for repetitive use shall  
be made from this document.

DASH NO.	ITEM	DESCRIPTION	COLOR
-1	GROMMET ASSEMBLY	ONE -2 COLLAR, ONE -3 FLANGE, ONE -4 SCREW	---
-2	COLLAR	---	CLEAR ANODIZE
-3	FLANGE	---	BLACK
-4	SCREW	SLOTTED HEAD	BLACK
-5	GROMMET ASSEMBLY	ONE -2 COLLAR, ONE -6 FLANGE, ONE -7 SCREW	---
-6	FLANGE	---	GRAY
-7	SCREW	SLOTTED HEAD	GRAY
-8	GROMMET ASSEMBLY	ONE -2 COLLAR, ONE -3 FLANGE, ONE -9 SCREW	---
-9	SCREW	PHILLIPS HEAD	BLACK
-10	GROMMET ASSEMBLY	ONE -2 COLLAR, ONE -6 FLANGE, ONE -11 SCREW	---
-11	SCREW	PHILLIPS HEAD	GRAY

NOTES:

- (C) 1. MATERIAL: COLLAR & FLANGE - 2011-T3 ALUMINUM ALLOY PER QQ-A-225/3  
SCREW - STAINLESS STEEL PER AMS 5640, TYPE I, AISI T-303
- (C) 2. FINISH: COLLAR & FLANGE - ANODIZE PER MIL-A-8625. COLORS SHALL CONFORM TO FED. STD. 595 FOR THE FOLLOWING COLOR NUMBERS AS CLOSE AS CAN BE ACCOMPLISHED BY COMMERCIAL ANODIZING PROCESS:  
BLACK LUSTERLESS #37038 FOR -3  
GRAY LUSTERLESS #36231 FOR -6  
CLEAR ANODIZE FOR -2  
SCREW - COLORS SHALL CONFORM TO FED. STD. 595 AS CLOSE AS CAN BE ACCOMPLISHED BY COMMERCIAL PROCESS:  
STANDARD BLACK LUSTERLESS #37038 FOR -4 & -9.  
GRAY EPOXY PAINT #36231 PER MIL-E-15090B FOR -7 & -11.
- (C) 3. DIMENSIONS IN INCHES. UNLESS OTHERWISE SPECIFIED, TOLERANCES: ± 0.10  
SCREW THREADS IN ACCORDANCE WITH FED-STD-H28
- (C) 4. REFERENCED DOCUMENTS SHALL BE OF THE ISSUE IN EFFECT ON DATE OF INVITATIONS FOR BIDS, OR REQUEST FOR PROPOSAL EXCEPT THAT REFERENCED ADOPTED INDUSTRY DOCUMENTS SHALL GIVE THE DATE OF THE ISSUE ADOPTED.
- 5. FOR DESIGN FEATURE PURPOSES, THIS STANDARD TAKES PRECEDENCE OVER PROCUREMENT DOCUMENTS REFERENCED HEREIN.

INTENDED USE:

ATTACHING MIL-P-7788 INFORMATION PANELS TO MOUNTING PLATES. THE CAPTIVE SCREW WHEN DISENGAGED FROM THE CAPTIVE NUT, CAN BE USED FOR LIFTING THE INFORMATION PANEL AND DISENGAGING THE ELECTRICAL CONNECTOR.

THE GOVERNMENT HAS A ROYALTY-FREE LICENSE UNDER U.S. PATENT APPLICATION SERIAL NUMBER 843,953 FILED ON JULY 23, 1969, ENTITLED "ADJUSTABLE SLEEVE FOR FASTENING SOFT MATERIAL PANELS TO HARD MATERIAL" FOR THE BENEFIT OF MANUFACTURE OF THIS ADJUSTABLE SLEEVE EITHER FOR THE GOVERNMENT OR FOR USE IN EQUIPMENT TO BE DELIVERED TO THE GOVERNMENT.

AMSC N/A

APPROVED 15 MAR 1971 REVISED (C) FOR CHANGES SEE SHEET 1 AND 2

P.A. NAVY - AS Other Cust AF - 11 ARMY - AV	TITLE	MILITARY STANDARD
	(C) SCREW ASSEMBLY, PANEL	MS 3498
PROCUREMENT SPECIFICATION MIL-P-7788	SUPERSEDES MS25381	SHEET 2 OF 2